



## FUCHS Aerobic Biosolids Digestion in an open tank



Aerobic Biosolids Digestion with FUCHS CENTROX Aerators is a cost-effective approach for sewage sludge stabilization used at many wwtps in Europe.

The extended aeration process of a wwtp in Germany was overloaded due to increasing inflow. As consequence simultaneous stabilization was not possible any longer. In 2014 an existing sludge storage tank was successfully retrofitted with a FUCHS CENTROX Aerator for post-stabilization.

The FUCHS CENTROX Aerator can be easily mounted in existing tanks. Floats are available to allow easy installation and vertical movement in case of varying sludge levels.

The FUCHS CENTROX Aerator aerates the sludge, mixes it and limits the foam layer in the tank. As a consequence the sludge is further stabilized and odours are limited.

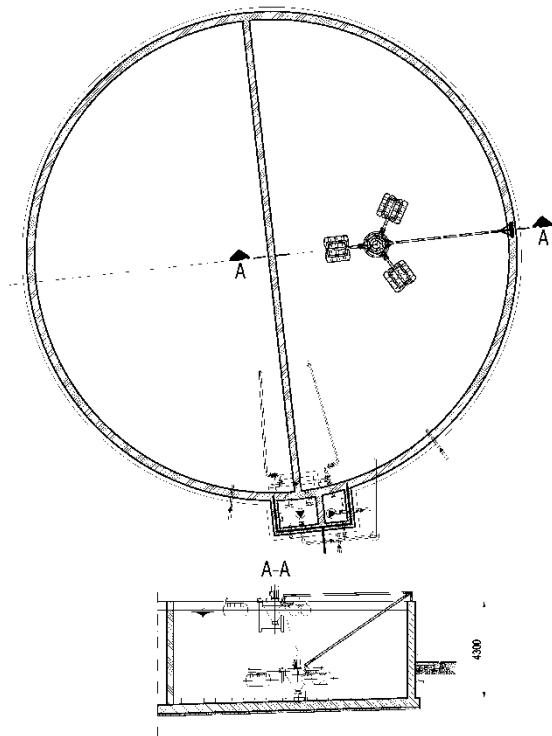

### Technical details

The original design load of the wwtp was 8,000 people (PE).

Currently about 11,000 people (PE) are connected to the wwtp in Odelzhausen. Thereof, about half is coming from industrial sources.

As a consequence the environmental authorities have put pressure on the operating company.

As a quick to implement solution the FUCHS CENTROX Aerator is the number one choice.

An existing storage tank was divided in two parts. One half is equipped with one FUCHS CENTROX Aerator with foam control on float. This part provides for further stabilization of the sludge.

The unique FUCHS CENTROX Aerators are the key part of the Aerobic Biosolids Digestion. CENTROX Aerators provide for aeration, mixing and foam control in one machine. They are designed for efficient aeration and easy operation. They are available with floats and for installation at a bridge, whatever suits best.

The advantages of the aerobic digestion with FUCHS CENTROX Aerators in short:

- further stabilization
- low investment costs
- very good process stability and reliability
- flexible operation
- efficient aeration
- good mixing
- limiting of the foam layer
- reliable Aerators made of high-quality materials,
- low maintenance Aerators
- proved at many installations

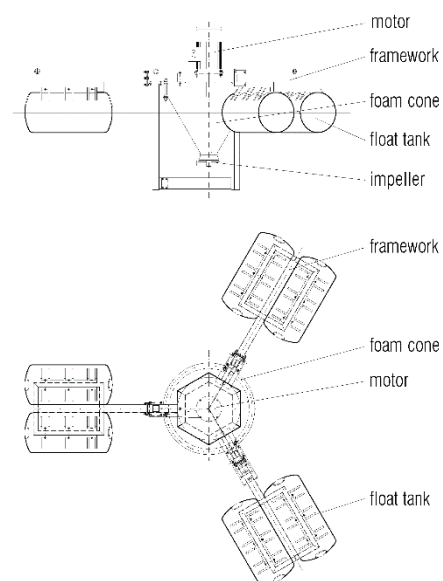



## Contact:



**FUCHS**  
A Metawater Company

**FUCHS Enprotec GmbH**

Stocktal 2 · 56727 Mayen · Germany  
phone +49 2651 8004 0  
fax +49 2651 8004 135  
info@fuchswater.com  
www.fuchswater.com